

*Maxair*<sup>TM</sup>

# **SPECIFICATIONS**

**FOR APPROVAL**

**Model: 8038B2HL**

**AC220V 50/60Hz 0.11/0.10A**

# Maxair™

## SPECIFICATION

<u>Item</u>	<u>Specification/Condition</u>
<b>Dimension</b>	: 80x80x38 mm
<b>Bearing System</b>	: BALL BEARING
<b>Rated Voltage</b>	: 220 VAC
<b>Operating Voltage</b>	: 200 VAC—240 VAC
<b>Start-up Voltage</b>	: 160 VAC NORMALLY
<b>Rated Current</b>	: 0.11/0.10 Amp NORMALLY
<b>Rated Power</b>	: 18/14 Watt NORMALLY
<b>Rated Speed</b>	: 2400/2900 RPM±10%
<b>Air Flow</b>	: 0.68/0.88 m <sup>3</sup> /min ( 24 /31 CFM)
<b>Static Air Pressure</b>	: 3.3/4.83mmH <sub>2</sub> O
<b>Noise Level</b>	: 31/35dBA
<b>Motor Protection Type</b>	: BY IMPEDANCE
<b>Life Expectance</b>	: 50000 Hours at Room Temperature
<b>Operation Temperature</b>	: -30°C to +75°C
<b>Net Weight</b>	: 260 Grams

# Maxair™

## MATERIAL

- 1. Impeller : Thermoplastic PBT of UL 94V-0
- 2. Bobbin : Thermoplastic PA66 of UL 94V-0
- 3. Lead Wire : UL 1430 AWG#22

## DIMENSIONS: MM

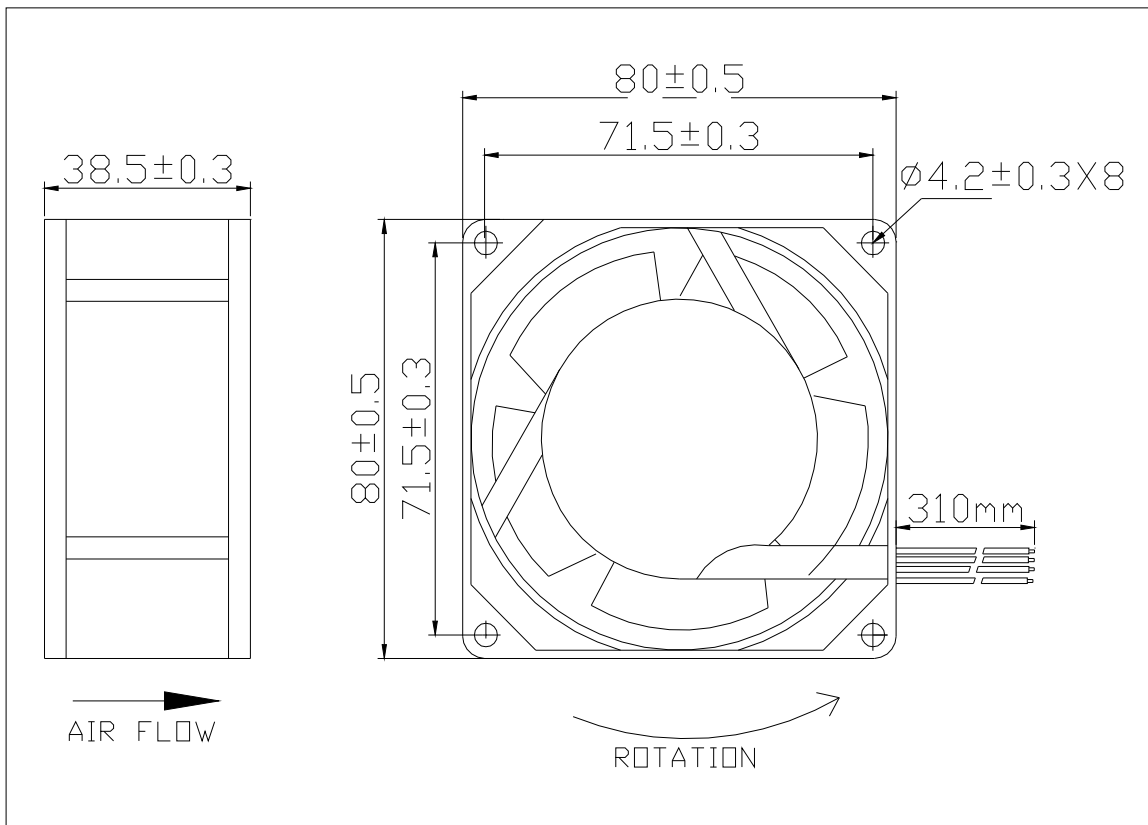

## Performance Curve

