

PPAC series / PPAC-XXAS series

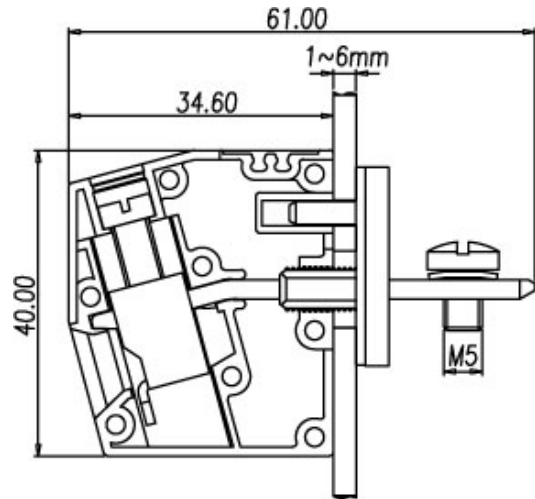

PPAC-16AS / PPAC-16ASG



Approval	UL	
Technical Data	UL	IEC
Rated voltage	300V	500V
Rated current	85A	101A
Conductor cross-section, solid (AWG / mm ²)	22~4 / 0.5~25	
Conductor cross-section, flexible (AWG / mm ²)	22~4 / 0.5~16	
Rated impulse withstand voltage	6KV	
Torque (N-m)	2.8	
Screw	M5	
Wire strip length	16mm	
Insulating material	PA	
Outer dimension TxHxW (mm)	12.1 x 40 x 34.8	
Inner dimension TxHxW (mm)	12.1 x 26 x 25.4	

	Accessories	Cat. No.
Marking label		TM28
Tool		



Dimension

