

1

2

3

4

5

6

7

A

B

C

D

E

F

G

H

A

B

C

D

E

F

G

H

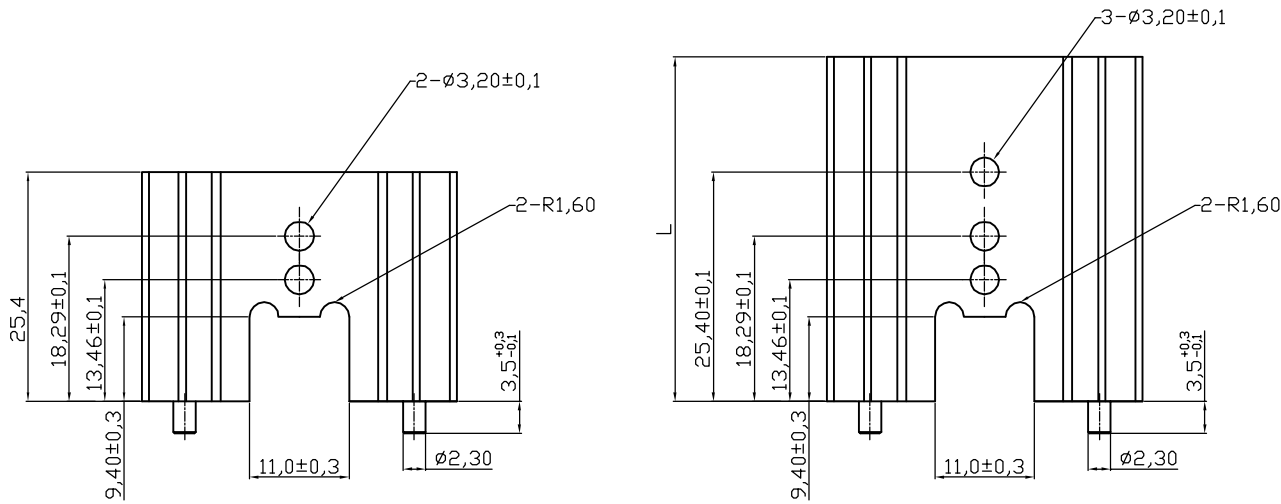

V7477W

V7477X/Y/Z

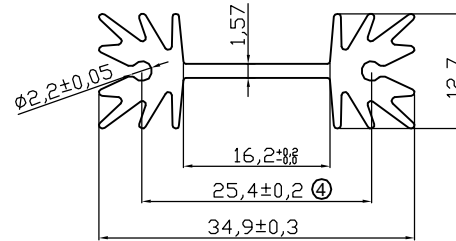

Material : AL 6063-T5  
 PIN: CRS Tin Plated  
 Finished: Black anozied  
 Unmarked round angle R is 5mm.

Option	L	Thermal resistance(K/W)
V7477W	25.4	14
V7477X	38.1	11
V7477Y	50.8	9
V7477Z	63.5	7

**RoHS compliant**  
 Unit: mm

Scale	FREE					Date	Name	
TOLERANCE		⑤	Change production plant	07.06.2013	Amy	Drawn	09.05.2011	Dean
X.	±X	④	Modify Dimention	09.05.2011	Jason	Approved	07.06.2013	Amy
X.X	±X	③	Modify Dimention	20.07.2010	Alex			
UNIT	±0.2	②	Modify drawing layout	08.03.2010	Dean			
DIM	Tol	①	Drawn	11.08.2009	Dean			
X.°	±X°							
X.X°	±X°							
Angle	TOL	Id.	Modification	Date	Name			

**ASSMANN**  
 WSW components

Customer-No.

ASSMANN WSW-No.

V7477x

Drawing-No.

ASS 0866 HS

rev05

Replace

Sheet